

CHANCE[®]

Series 90

Portable Capstan Hoist

Owners Manual

⚠ CAUTION

The equipment covered in this document should be installed, used, and serviced only by competent personnel familiar with and following good work and safety practices. This equipment is for use by such personnel and is not intended as a substitute for adequate training and experience in safe procedures for this type of equipment.

This information and any related documents do not cover all details or situations in equipment use nor do they provide for every possible contingency to be encountered in relation to installation, operation or maintenance. Should additional information and details be desired, or if specific situations arise which are not covered adequately for the user's purpose the specifics should be referred to the A.B. Chance Company.

NOTE: Since the Chance Company has a policy of continuous product improvement, it reserves the right to change design and specifications without notice.



P308-0880
Rev. C

A. B. Chance Company
210 North Allen Street
Centralia, MO 65240 USA

©Copyright 2003 Hubbell/Chance., Centralia, MO 65240 USA

P308-0880
Rev. C

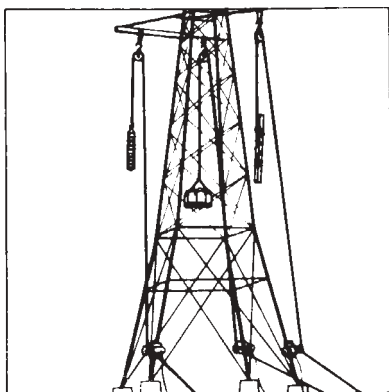

Figure 10a

Tower Work

Using the hoist, large crossarms, strings of disc insulators and cans of paint can be pulled up onto steel transmission towers.

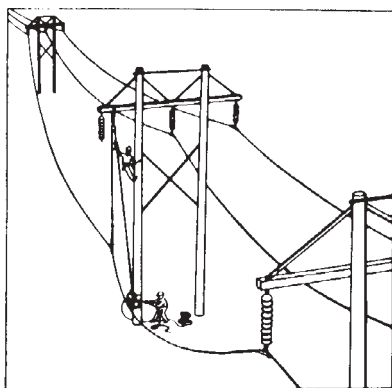

Figure 10b

The hoist also can be used to lower and raise conductors (de-energized and grounded) so that splices, patch rods, repair of damaged conductor sections and other mid-span work can be performed on the ground.

⚠ CAUTION

Under extreme loading, when operating an electric hoist from a limited power source such as a truck driven generator, the hoist motor may stall before reaching maximum capability. The hoist should not be operated under these conditions to avoid damage to the motor.

⚠ WARNING

Polypropylene rope is seriously weakened whenever use of it generates friction heat. This is particularly true if it is used over a capstan. Because of this condition, the continued slipping of polypropylene rope over a capstan should be avoided. Poly-Dacron rope is suggested as it has a higher heat resistant capability.

⚠ DANGER



Overhead loads can fall.

Will cause damage to equipment, severe injury or death.

Do not allow people to stand under or near the load.

Keep rope securely on capstan drum and under control by the operator.

Do not remove wraps of rope from the drum while supporting a load.

Do not allow the rope to overwrap itself or to ride up over the end of the drum flange.

⚠ WARNING

Read all instructions and follow your Company work rules.

Use only with mounts authorized by A.B. Chance Company.

Do not obscure or remove this label.

Do not use this hoist unless you are properly trained.

Do not lift more than rated load.

Do not use if damaged or malfunctioning.

Do not lift people or loads above people.

Do not stand between load and hoist.

Do not tangle fall line with operator or equipment.

Do not hold loads suspended in the air.

Do not remove wraps of rope from drum while supporting a load.

Maintenance

Except for repairing accidental damage, the hoist should not require any maintenance. If it is damaged or does not function properly, do not use, but tag and return it to the manufacturer for repairs.

Parts and Operation

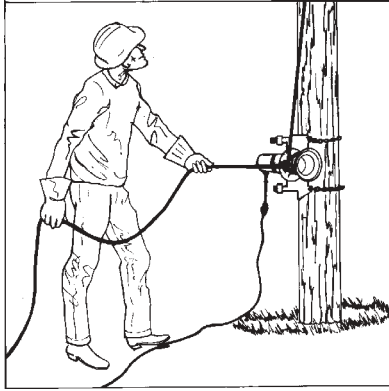

⚠ WARNING
Do not operate hoist without foot switch. Loss of control, damage, injury or death could result.

Foot Switch

The hoist is provided with a water-resistant foot switch which leaves both hands free for the capstan operation.

Figure 4a

Capstan

The proper method of wrapping the rope around the capstan for optimum rope action is shown in Fig. 4b. Wrapping the rope in the manner will place the “load wrap” on the inboard end of the capstan where the diameter is the smallest. This provides a stable condition for the rope to feed smoothly over the capstan without jumping or changing position for both raising and lowering loads.

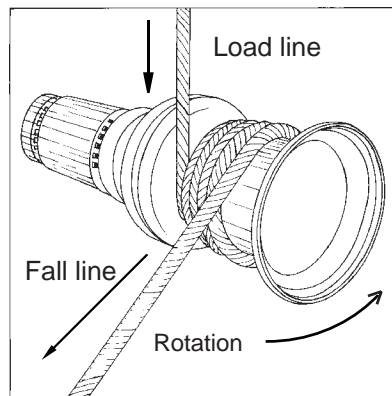

Figure 4b

⚠ WARNING

Never place “Load Line” near outboard (large) end of drum as damage and/or injury could result.

Rope Wraps on Capstan (Drum)

It is important to use the proper number of rope turns. Many variables (such as the load to be raised, amount of mechanical advantage in the tackle, size and age of rope) affect the number of turns. The final determination is made by “feel”. “Feel” is the amount of force required to keep the rope just tight enough around the capstan to raise or lower a load. With the proper number of wraps, a slight (approximately 20-lb.) pull should raise or lower a load. Adding wraps decreases the amount of pull required to control the load. Removing wraps increases the amount of pull required. **Notice:** Before learning this technique, there is a natural tendency either to pull harder than necessary or, conversely, to use an excessive number of turns.

Pulling Pole Stubs

Pulling pole stubs located in private property can be facilitated by using the portable hoist as shown in Fig. 9a. To lessen the required pulling force, the ground should be broken loose all around the stub before attempting to pull it.

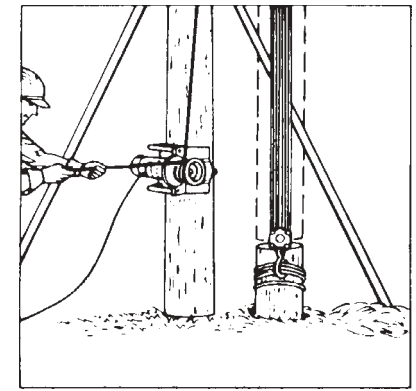

Figure 9a

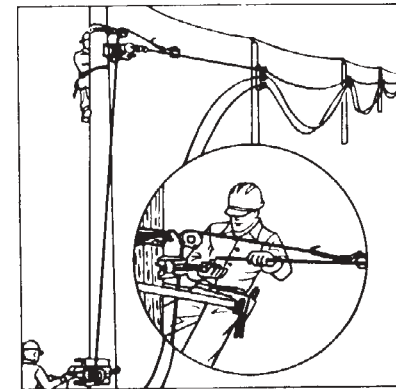

Figure 9b

Sagging Wire (De-energized and grounded)

Using the hoist, a handline and come-along, wire can be pulled in and up to sag as shown in Fig. 9b. This method is particularly useful in new subdivision work for putting up and sagging secondaries.

Pulling Cable

The hoist can be used for some cable pulling jobs. It is particularly handy for pulling cable to pad-mounted transformers located on private property.

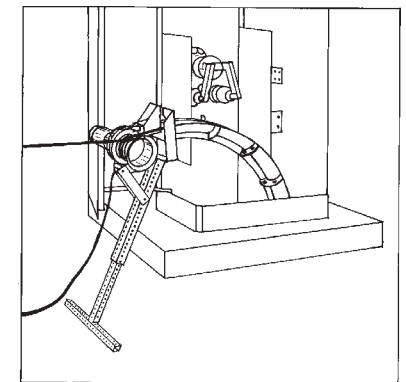

Figure 9c

Raising and Lowering Transformers, Setting Poles

Using the portable hoist as shown in Fig. 8a and 8b, transformers can easily be raised and lowered and replacement poles easily and safely set.

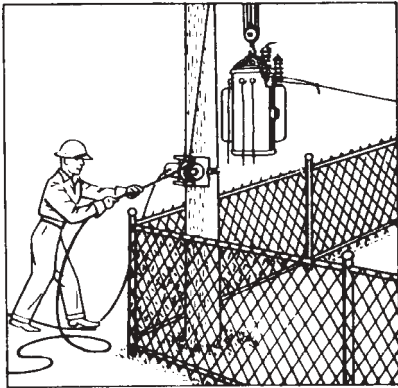

Figure 8a

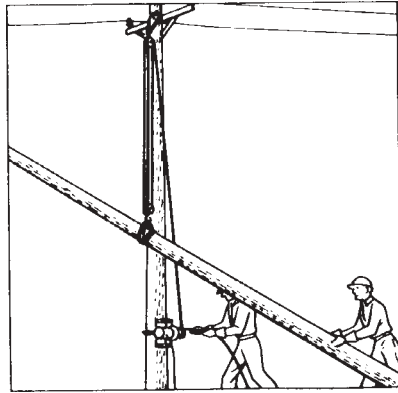

Figure 8b

The hoist is particularly valuable for private property work since it eliminates the necessity of a worker to relay signals between the workman on the pole and truck parked in the street. Use of the hoist also allows all the workers to be in the immediate job area for maximum control over all hoisting or lowering operations.

⚠ WARNING

A load should never be raised by taking so many wraps around the capstan that the operator is not required to pull rope off the capstan as it turns. This could result in the rope overwrapping, causing loss of control of the load and injury.

The best method for lowering a load is with the hoist motor running. Although the capstan turns in a direction opposite that of the rope when doing so, rope action on the capstan is smoother than merely allowing the rope to slip on a stationary capstan.

If, however, starting the hoist before lowering a load could raise the load and thereby cause an unsafe condition, lower the load by just slipping the rope without rotating the capstan. When the load is in the clear, rotate the capstan by running the hoist motor for smoother rope action.

Rope Lock Device (optional)

Lifting the cam lever opens the rope lock so that the fall line can be placed into the rope guide. After the rope is in place, release the cam lever. The unit now is in operating position.

To remove the rope from the guide, lift the lever, as for inserting rope.

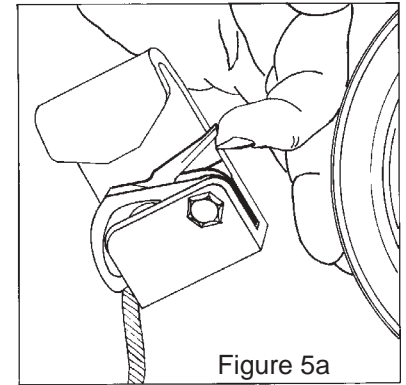

Figure 5a

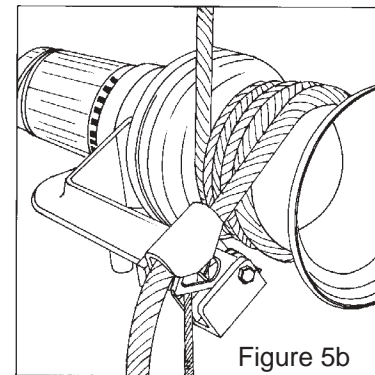

Figure 5b

The cam allows the rope to freely travel through the guide toward the operator pulling on the fall line. When the operator releases the fall line, the cam rotates, locking the rope in the guide.

To lower a load, the operator first pulls on the fall line, then pulls the cam open with the small lanyard. The cam must be held open for load lowering.

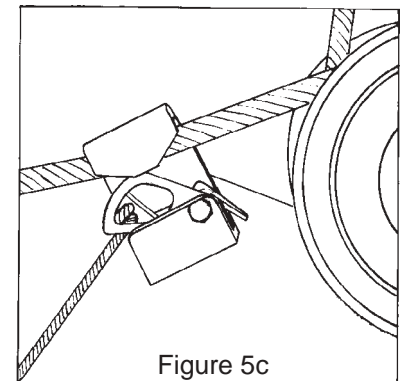

Figure 5c

Mounting on Pole

Remove the bolts in chain tubes (at wheel-tightener end) to allow tubes to pivot. Prior to mounting the hoist, open the binder all the way by turning the handle counterclockwise.

Drape the top chain over the capstan drum, hold the hoist against the pole with the upper leg, Fig. 6b. This leaves both hands free to grasp the top chain and extend it forward around the pole as if hugging it. Exchange the chain from hand to hand behind the pole so the chains can be hooked into the slots on the bracket.

The hoist is securely held to a pole, tree or other object by a screw-type binder. After hooking the chain, turn the binders clockwise to secure the hoist as shown in Fig. 6c. After heavy initial loading, it may be necessary to again tighten the binders by taking additional turns on the handles.

Mounting on Tower or Beam

Be sure the two bolts (at wheel-tightener end of chain binders) are secured in place through binders and bracket, Fig. 6a. This forms a 90°-shoulder between the chain binders and the bracket base for mounting the hoist to a square-cornered member. This is the only difference from other steps in the pole-mounting procedures, above.

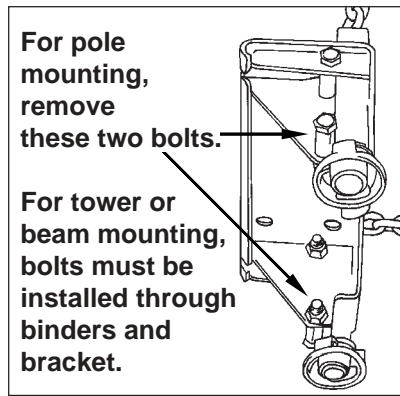

Figure 6a

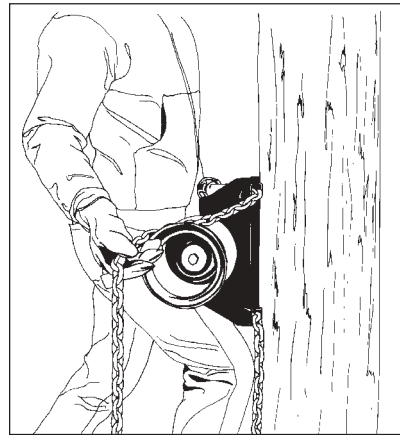

Figure 6b

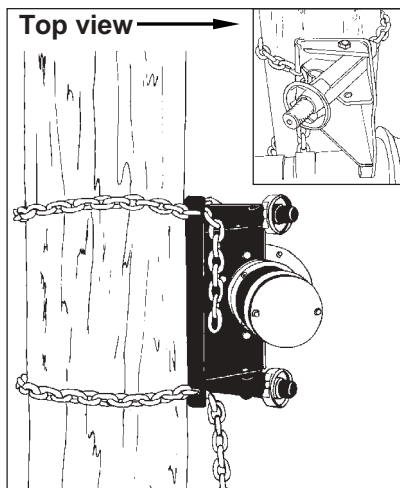

Figure 6c

APPLICATIONS

Pulling Transformers and Poles

Using the portable hoist and the fall line from a set of blocks, transformers and poles can be pulled from the truck to rear property lines, Fig. 7a and 7b. This method offers several advantages over using truck winch power.

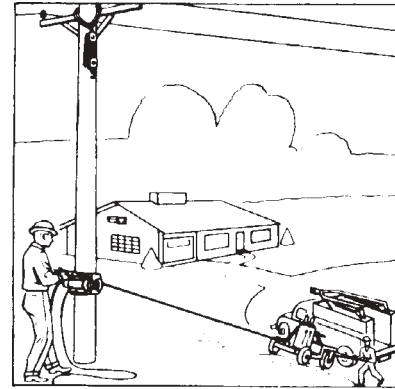

Figure 7a

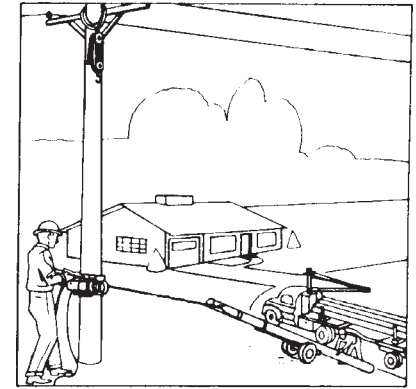

Figure 7b

These advantages can readily be seen by comparing Figs. 7a and 7b to Fig. 7c. It should be noted that the rigging in Fig. 7c not only requires a piece of rope twice as long as in Fig. 7a and 7b, but also the additional sling and snatch block at rear lot line. Rigging with the portable hoist as shown in Fig. 7a and 7b also eliminates the hazard of tripping over and the obstacle of working around the return rope to the truck.

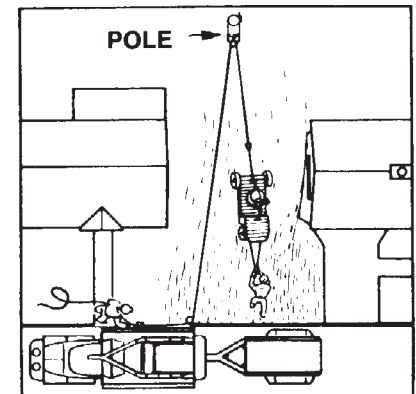

Figure 7c